

Cable Track Conveyors



Cable conveyor was one of the first conveyor designs to be used for conveying containers over a distance. Primarily used for empty cans, the design of the cable conveyor has been changed over the years to fit into most container applications.

Container Handling Systems Corp. has upgraded specifications and materials to meet the changes in container design, line speeds and applications. Whether it be the cable or the type of side rails, you can be sure that Container Handling Systems Corp. has the latest materials and design to meet your particular requirements.

The following pages illustrate many different components and their use, along with the specifications of the equipment. The engineering department at Container Handling Systems Corp. is trained in every area in using cable conveyor and can furnish you a complete engineered package of equipment, pre-wired control systems and field installation.

SPECIFICATIONS

DRIVE AND TAKE-UP UNITS

FRAMES:

3/16" x 1 1/2" angle, with all bolt on construction

- A. mild steel, painted
- B. aluminum
- C. stainless steel

DRIVE SHEAVES:

18" dia. (single or double groove) cast iron sheave on a 1 1/4" shaft, pillow block bearings

- A. cold roll shaft
- B. stainless steel shaft
- C. cast iron bearings
- D. nickle plated bearings

TAKE-UP OR IDLER SHEAVE:

15" dia. single groove cast iron sheave on a 1" dia. shaft, pillow block bearings, 1" dia. x 30" take up screw with compression spring, aluminum hand wheel, aluminum take-up slide.

- A. cold roll shaft
- B. stainless steel shaft
- C. cast iron bearings
- D. nickle plated bearings

DRIVE PARTS AND GUARD:

No. 60 carbon steel roller chain, 'B' style hubs, four-sided guards with wing nuts for easy removal, top mounted motor base.

- A. taper lock sprockets
- B. mild steel painted guards
- C. stainless steel guards

CORNER TURN ASSEMBLIES

SHEAVES:

12" dia., 15" dia., 18" dia. sheaves, top sheaves machined to expose cable above cast iron sheave, 1" dia. shaft with grease fittings for ER style bearings.

- A. 1" dia. shaft
- B. 1 1/4" dia. shaft

FRAMES:

4" main channel, aluminum bearing block with adjusting screws

- A. mild steel painted
- B. aluminum
- C. stainless steel

CORNER BANDS:

Plastic covered half round or 1/8" x 1 1/2" stainless steel, (stainless steel half round top rail).

CABLE CONVEYOR

CONVEYOR FRAME:

3/16" x 1 1/2" x 2" angle with slots on 1 1/2" side of angle, 20'0" standard length

- A. mild steel, painted
- B. aluminum
- C. stainless steel

SIDE RAIL UP-RIGHTS (QUICK ADJUSTABLE):

Cast Al-mag parts

- A. mounted on 20" or 40" centers
- B. plated or stainless steel adjusting screw and fasteners

SIDE RAIL UP-RIGHTS (NON-QUICK ADJUSTABLE):

Formed 1/4" x 1 1/2" up-right on cross channel, channel slotted for adjustment

- A. mounted on 20" or 40" centers
- B. plated assembly and fasteners
- C. stainless steel assembly and fasteners

CABLE CANNING WAYS:

- A. plated 3" dia. sheaves with UHMW plastic pressed bearing, mounted on 10"-20" or 40" centers
- B. UHMW plastic (green) 3" dia. sheave with metal busing mounted on 10"-20" or 40" centers
- C. "Arguto Wood" continuous carrying way on aluminum channel
- D. "Arguto Plastic" continuous carrying way on aluminum channel

SIDE RAILS:

- A. 1/2" x 1 1/2" brite stainless steel or galvanized (used as top rail)
- B. UHMW plastic capping for above
- C. aluminum "Mini-Rail" with paint contact or flat contact UHMW plastic insert

CABLE:

- A. "Rochester" 6 x 19 galvanized with nylon covering
- B. "Bethlehem" 6 x 19 galvanized
- C. "Volta" plastic with fiberglass core

HANGERS

FRAME:

3/16" x 1 1/2" angle, 1/4" x 1 1/4" flat stock crossbracing, all bolt on construction, vertical and horizontal slots for optimum adjustment

- A. mild steel, painted
- B. aluminum
- C. stainless steel

Whatever the application calls for, environmental, performance or container characteristic problems, our wide range of specifications allows our line of cable conveyor and components to fit into most applications.

In addition to the standard listed specifications, custom designed equipment is available upon request. Most any type of drive package can be accommodated.

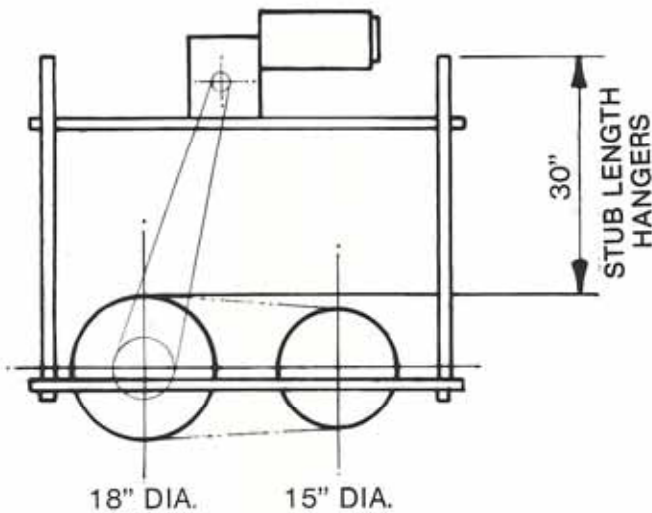

DOUBLE GROOVE DRIVE UNIT

This is the standard cable drive unit used on intermediate conveyor lengths of (100 ft.) to long conveyor lengths of (300 ft.). The double groove drive should be used on all full container applications. No take-up available on idler sheave.

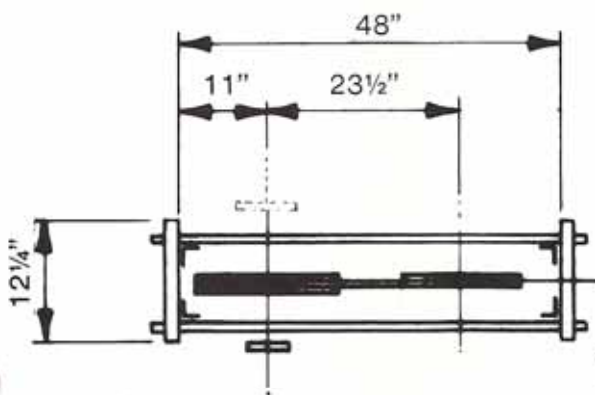

DOUBLE GROOVE DRIVE UNIT

INLINE DRIVE/TAKE-UP UNIT

(MERRY-GO ROUND DRIVE)

The inline unit is used for an endless loop conveying system with containers passing through the frame. It can also be used as the end drive unit when a fixed idler unit is used at the opposite end. This unit has the drive power in between a single groove and double groove drive unit. The same amount of take-up is available as the standard take-up unit. This unit can be used on the return side of the cable when both the drive and idler are fixed.

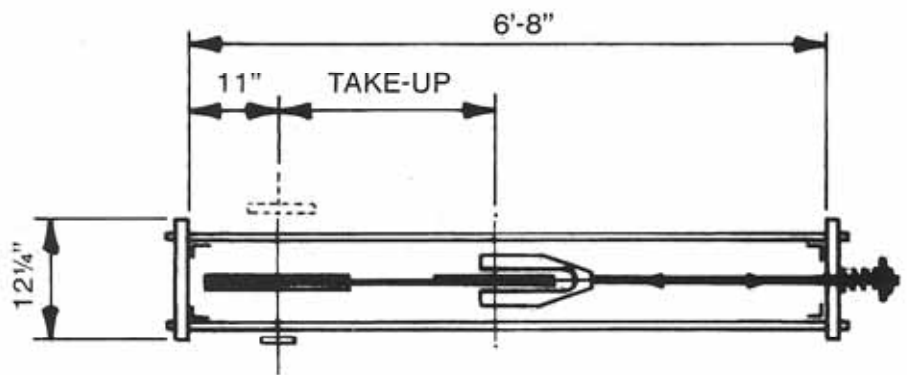
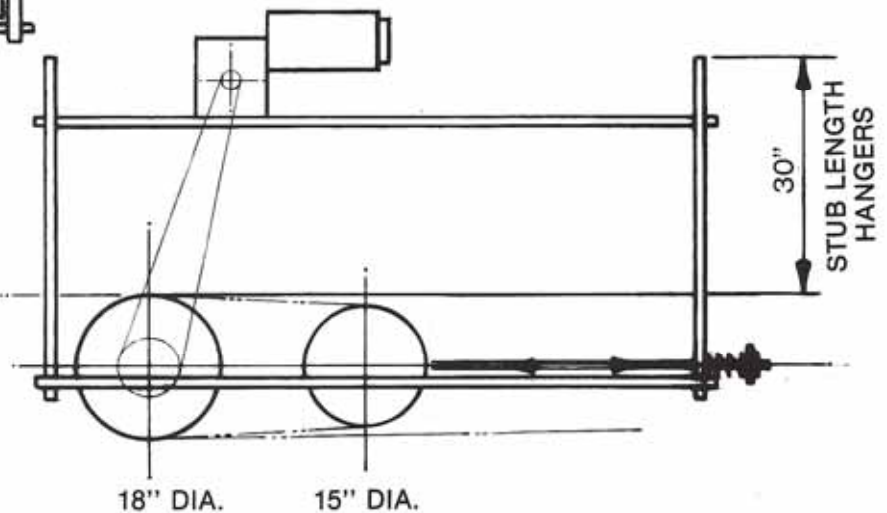

INLINE DRIVE/TAKE-UP UNIT (MERRY-GO ROUND DRIVE)

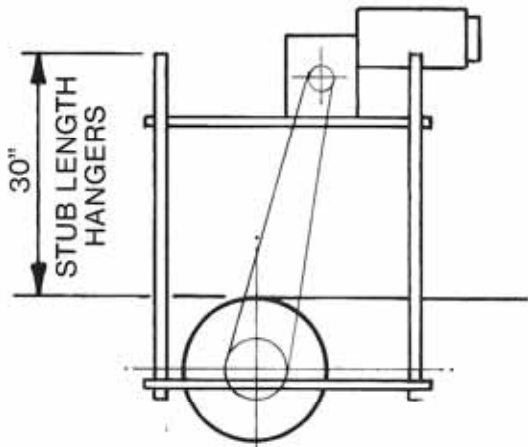

18" DIA. (DRIVE)
15" DIA. (IDLER)

**SINGLE GROOVE DRIVE UNIT
or
FIXED IDLER UNIT**

The single groove drive should be used on conveyor lengths under 100 ft. and should not be used for full containers. The same frame is used on fixed idlers (18" dia. sheave on drive and 15" dia. sheave on fixed idlers). The fixed idler frame is used when a take-up is used elsewhere on the system.

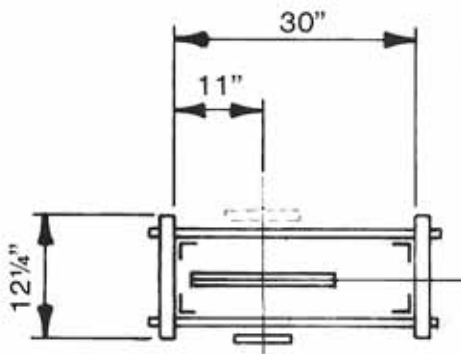

**SINGLE GROOVE DRIVE UNIT
or
FIXED IDLER UNIT**

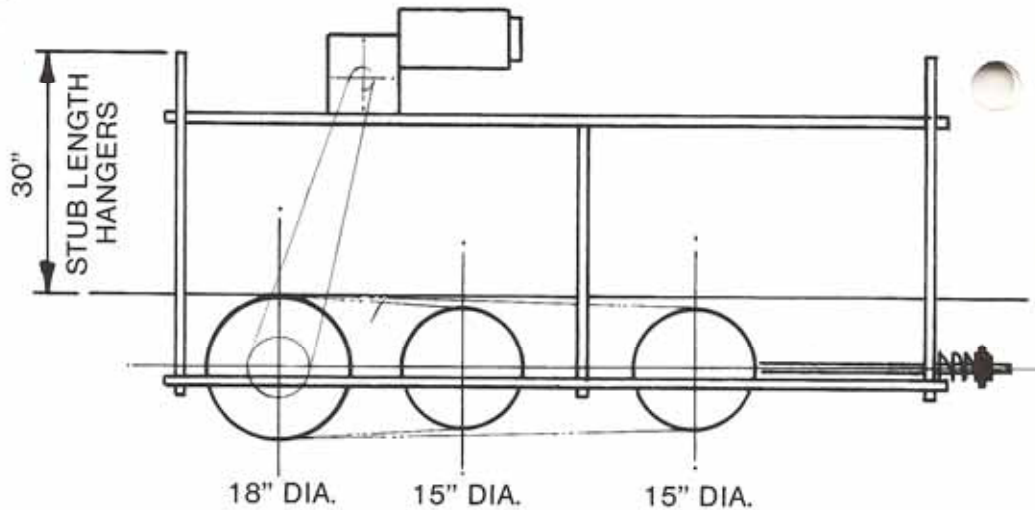

18" DIA. 15" DIA. 15" DIA.

**COMBINATION DRIVE/
TAKE UNIT
(CABLE TRANSFER)**

The combination unit is an all one-piece frame used to transfer containers from cable to cable without a dead plate when conveyor lengths exceed 300 ft. The drive unit is a standard double groove drive and requires a take-up unit on the idler end. The back end is a standard take-up unit and requires any type of drive unit depending on the application.

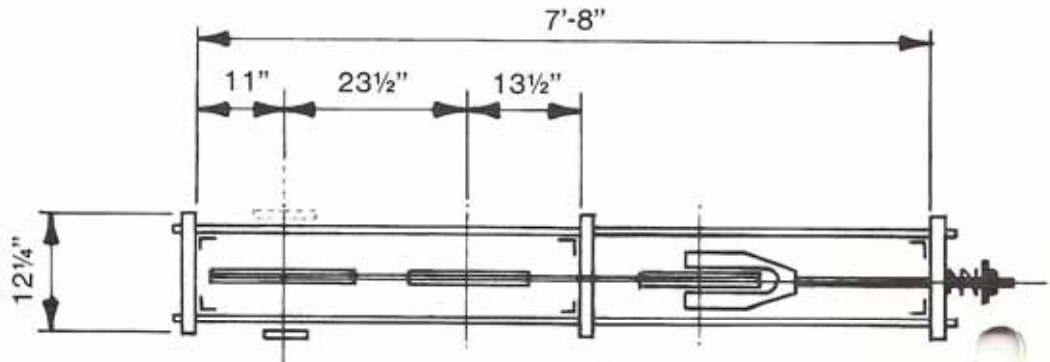

**COMBINATION DRIVE/TAKE UNIT
(CABLE TRANSFER)**

**TAKE-UP UNIT
(PUSH OR PULL TYPE)**

The standard take-up unit has a 30" adjustment screw to handle conveyor lengths of 300 ft. This is the unit to use with any fixed type drive. The take-up can be used in any push or pull application.

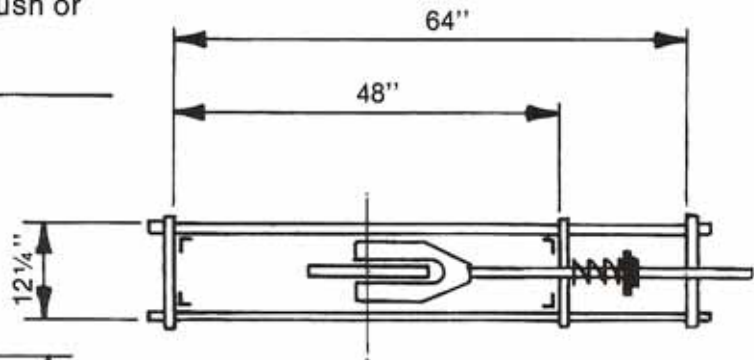
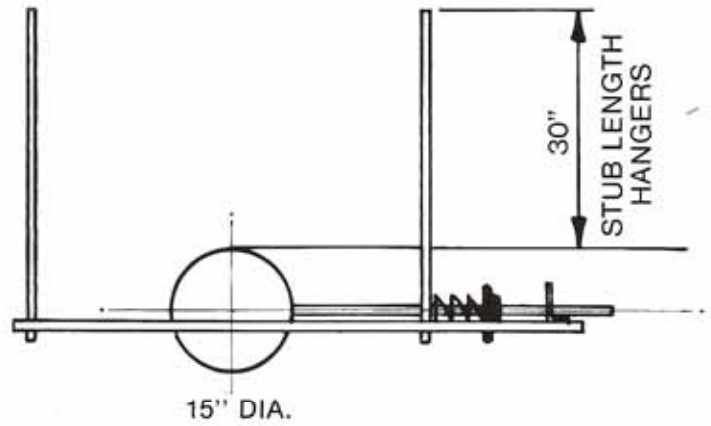

**TAKE-UP UNIT
(PUSH OR PULL TYPE)**

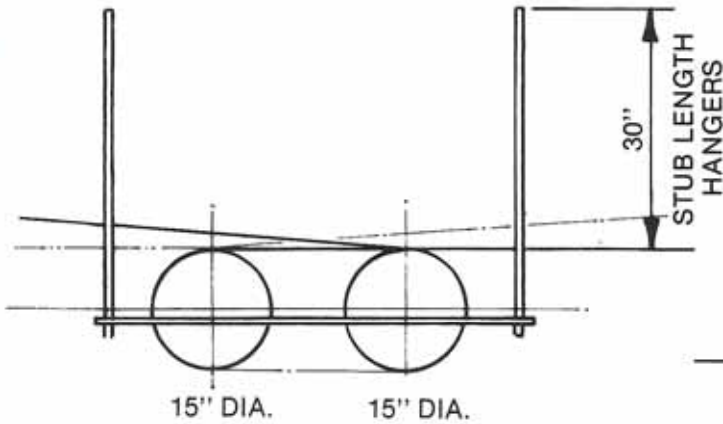

**INCLINE/DECLINE UNIT
(DECLINE IN OR INCLINE OUT)**

The incline/decline unit is a non-powered unit used when changing the slope of the conveyor line from level to up or down to level. The 15" dia. sheaves are machined to expose the cable for a smooth container transfer.

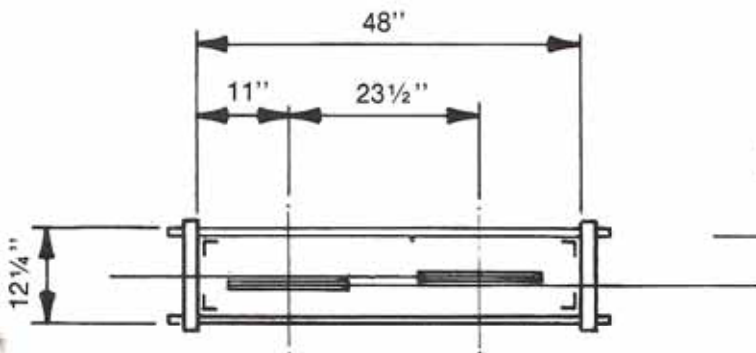

**INCLINE/DECLINE UNIT
(DECLINE IN OR INCLINE OUT)**

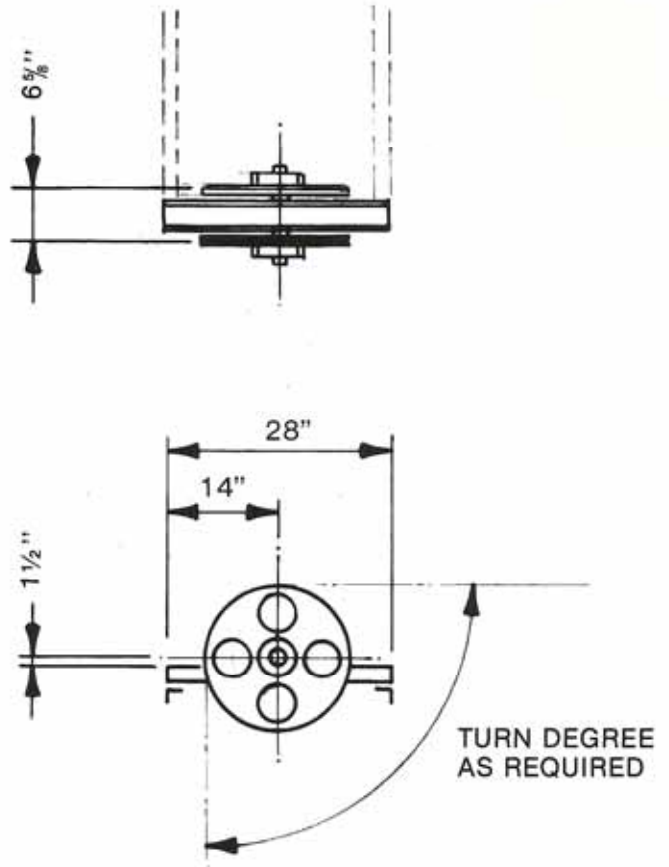
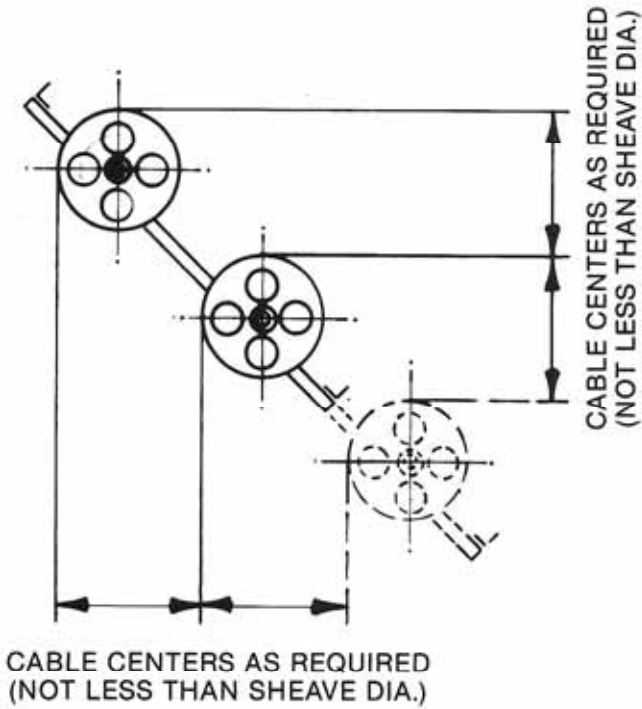

CORNER TURNS AVAILABLE IN
12" - 15" - 18" DIA. SHEAVES

All corner turns (12" dia.-15" dia. [std.]-18" dia.) are machined to expose the cable going around the turn. The container rides the cable not the corner turn casting for the best transfer possible. All corner turns have double "ER" style bearings with grease fittings for lubrication which allows minimum friction. A complete selection of corner turn guide rails are available to match the conveyor guide rails. All corner turn assemblies have adjusting screws for easy field installations when sloping conveyor in and out of the turn.

All cable conveyor and components are supported by angle type hangers. In addition to the rigid legs, cross bracing is used to reduce the possibility of conveyor sway. These hangers are designed with proper adjusting slots that allow easy and accurate field installation.

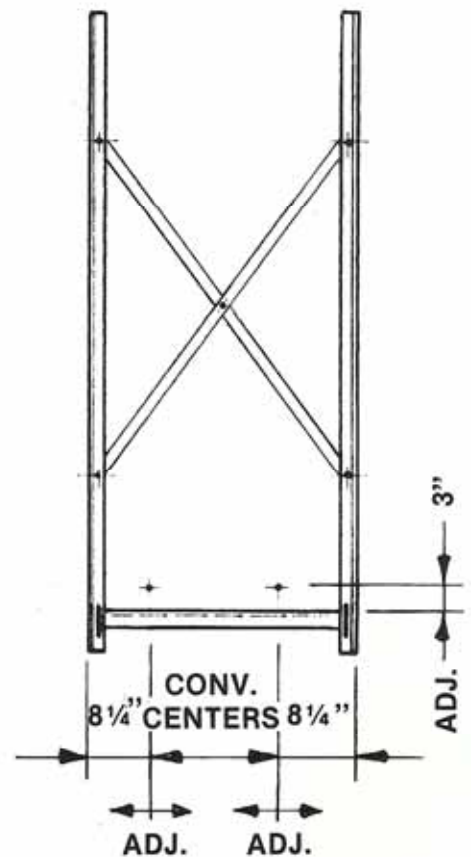

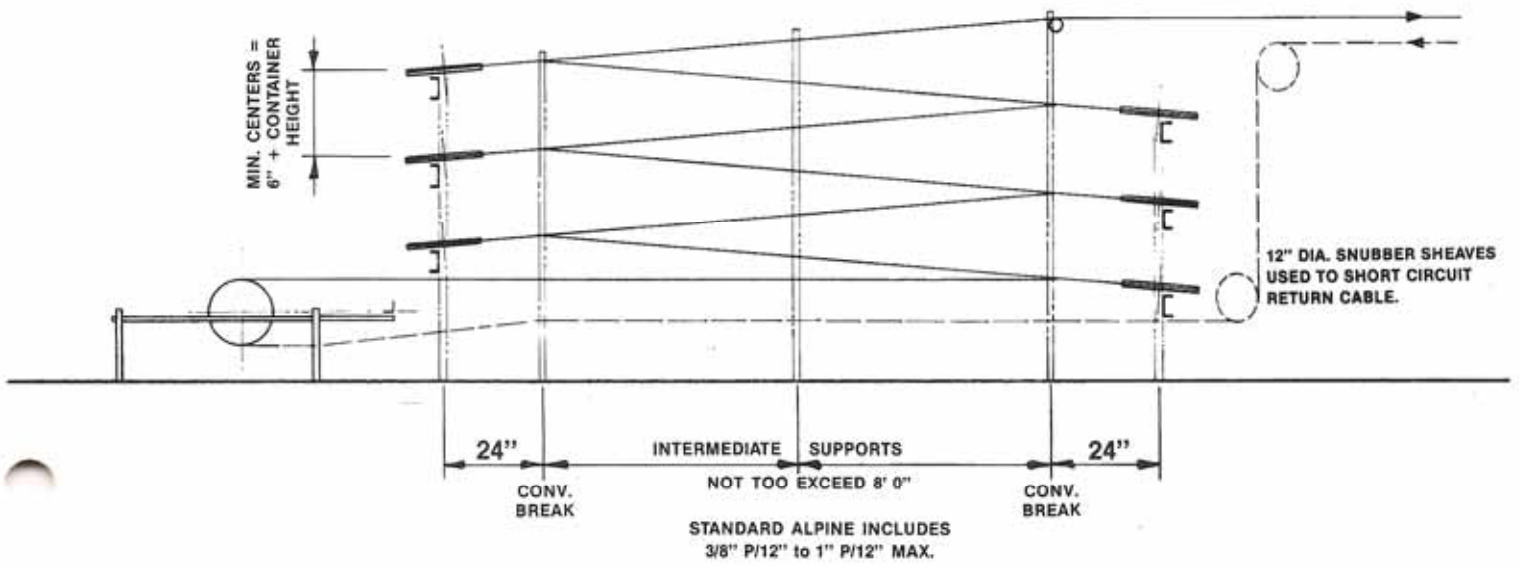
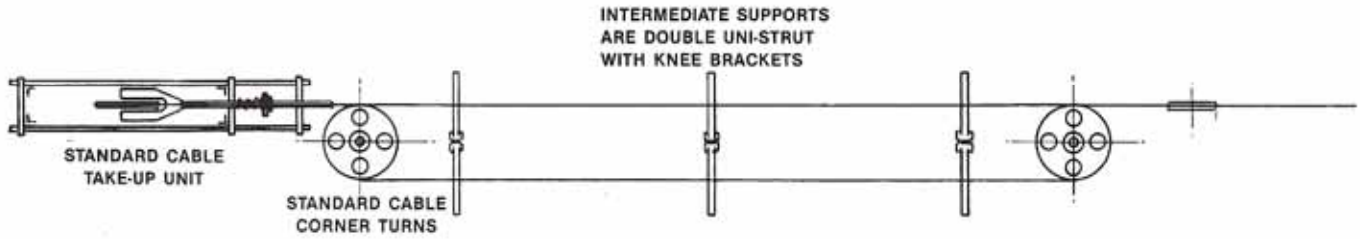

One of the best cable conveyor applications is the use of the "Alpine" system. An elevator or lowerator alpine can be accumulated on where an elevator must be stopped when containers back up. By matching the container with the proper incline, the alpine is the best method to change elevations at high-speed production rates.

With Container Handling Systems Corp.'s pre-engineered alpine systems, much of the field installation is done at our plant. Most components are made with complete adjustments in supports and corner turns. Alpine corner turn towers can be made shipped complete with 60" long conveyor lengths and corner guide rails pre-installed.

When operating with multiple container diameters, the quick adjustable side rail style conveyor should be used. A hand crank attached to a threaded rod opens or closes the side rails. The adjustable saddle is made of "Almag" for durability. A complete selection of accessories are listed in the specification section of this booklet.

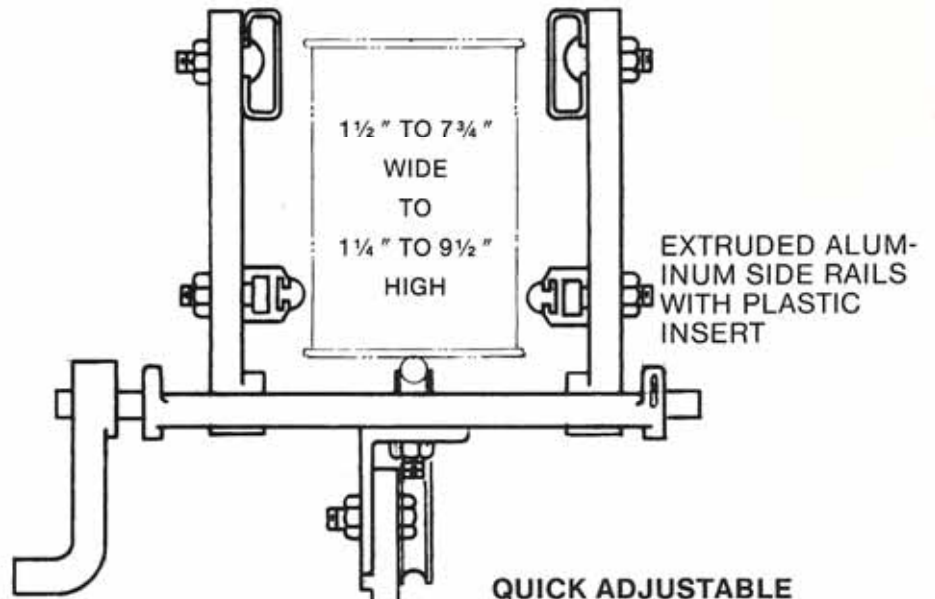

EXTRUDED ALUMINUM SIDE RAILS WITH PLASTIC INSERT

QUICK ADJUSTABLE STYLE CONVEYOR WITH SHEAVE TYPE CABLE CARRYING WAY

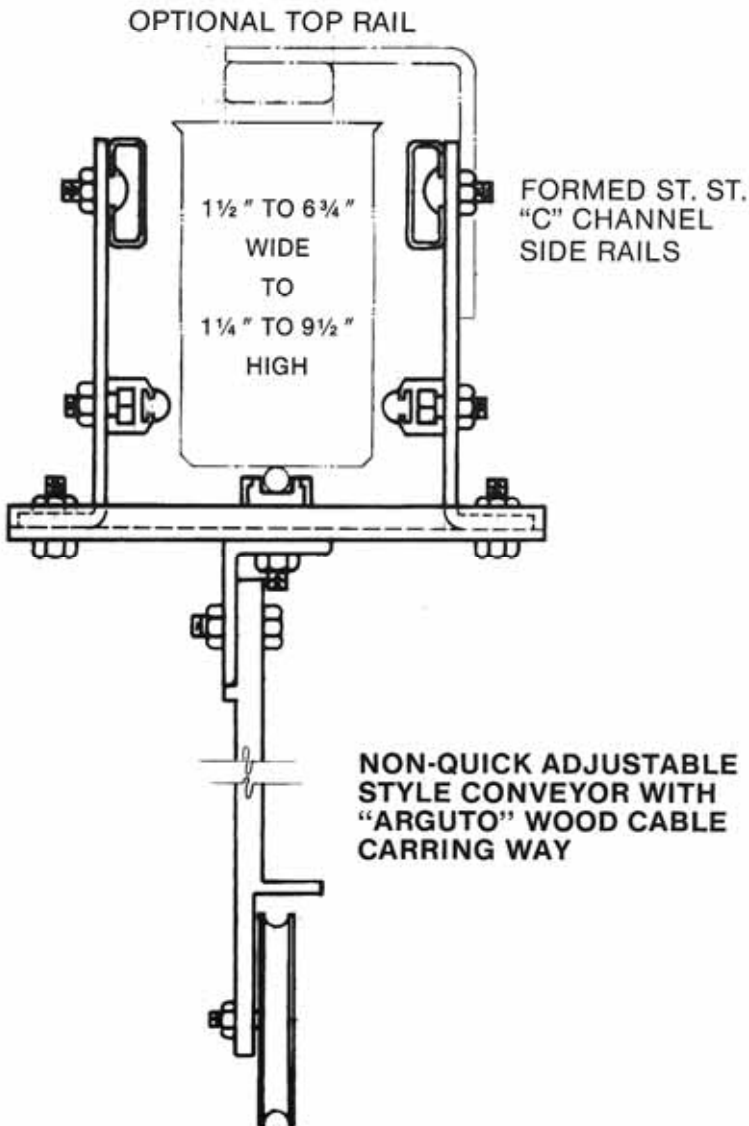

OPTIONAL TOP RAIL

FORMED ST. ST. "C" CHANNEL SIDE RAILS

NON-QUICK ADJUSTABLE STYLE CONVEYOR WITH "ARGUTO" WOOD CABLE CARRYING WAY

RETURN CABLE BRACKETS

The most economical style of cable conveyor when operating a single container size. The non-quick adjustable side rail saddle has a slot adjustment in the event the container size may change in the future. All accessories are also available for this style of conveyor as well.