

EMPTY CAN MAGNETIC ELEVATORS

Container Handling Systems' Empty Can Magnetic Elevators have been designed to fit into any application of container size and line speed. Each of the two styles of elevators has their own designed applications.

Side Discharge — This is the basic configuration of our Empty Can Magnetic Elevator. Its size and discharge locations will lend itself to any line layout. Ideal for all standard round size containers.

Over the Hump Discharge — This is the ideal elevator for the larger and non-round size containers. The large sweeping radius on the horizontal transition helps eliminate tipping when making the transition for the larger containers.

Both styles of elevators have a selection of optional equipment to custom fit the elevators into your specific operation.

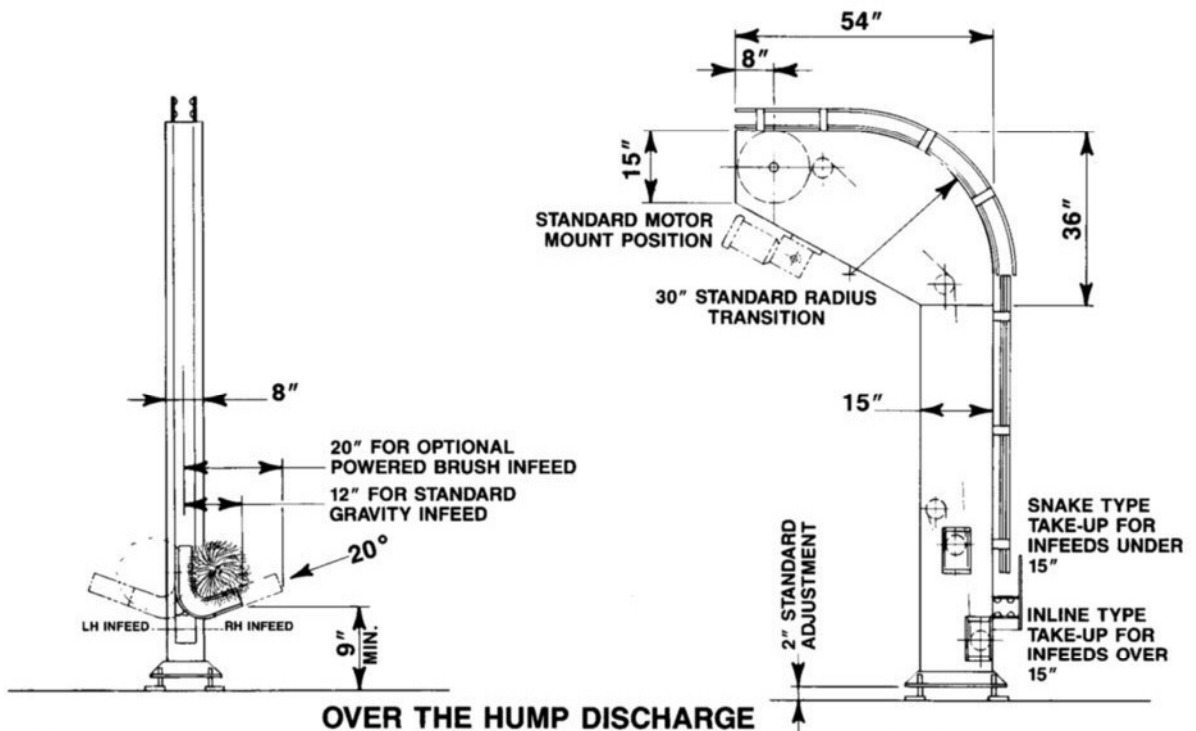

OVER THE HUMP DISCHARGE

SPECIFICATIONS:

FRAME: Mild Steel Painted, 11 GA.
Polished Aluminum, 11 GA.

BELT: 4" or 6" wide thin, smooth top with slip back belting, continuous glued splice 3/4" or 4 1/2" plastic table chain.

DRIVE PULLEY: Urethane coated 15" dia. pulley with snubber pulley for 270° wrap.
41 tooth sprocket for table top chain.

MOTOR DRIVE: Any style motor drive with No. 50 roller chain.

MAGNETS: Permanent ceramic style magnetic rail/ware plate with diminishing magnetic field at infeed and discharge.

INFEEDS/DISCHARGES: St. St. polished (or plastic covered) half round rails, side rails to match.
Standard infeeds are gravity roll in with optional powered 15" dia. brush.

Side Discharge Elevator has powered 15" dia. brush as standard.

MOTOR REQUIREMENTS:

	OVER THE HUMP	SIDE DISCHARGE
10 Ft. Lift	1 1/2 HP	1 HP
15 Ft. Lift	1 1/2 HP	1 1/2 HP
20 Ft. Lift	2 HP	1 1/2 HP
25 Ft. Lift	3 HP	2 HP

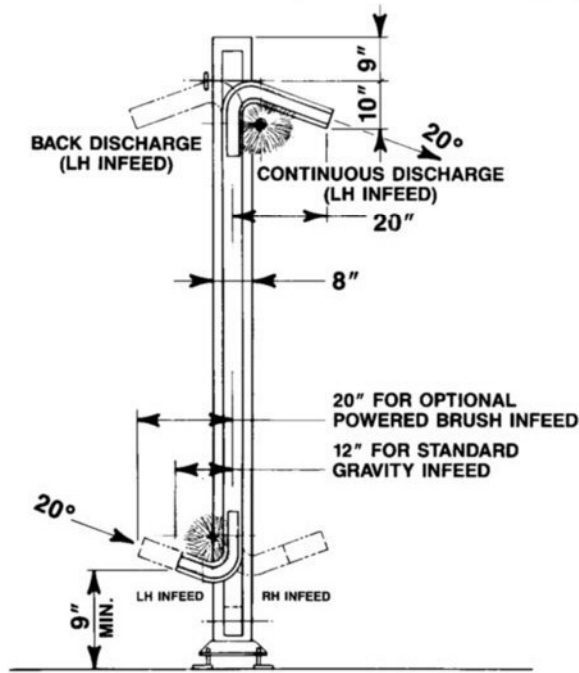

SIDE DISCHARGE

